

UL File No.: E43149; CSA File No.: LR26550

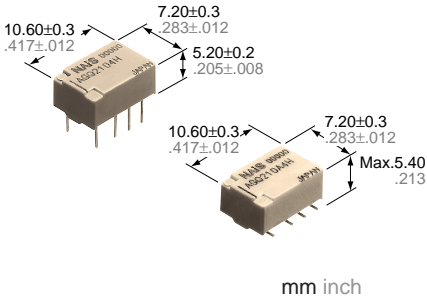

mm inch

• Compact flat body saves space

With a small footprint of 10.6 mm (L) × 7.2 mm (W) .417 inch (L) × .283 inch (W) for space savings, it also has a very short height of 5.2 mm .205 inch. (Standard PC board type.)

• Outstanding surge resistance.

Surge withstand between open contacts: 1,500 V 10×160 μs (FCC part 68)

Surge withstand between contact and coil: 2,500 V 2×10 μs (Bellcore)

• The use of twin crossbar contacts ensures high contact reliability.

AgPd contact is used because of its good sulfide resistance.

Adopting low-gas molding material.

Coil assembly molding technology which avoids generating volatile gas from coil.

• Increased packaging density

Due to highly efficient magnetic circuit design, leakage flux is reduced and changes in electrical characteristics from components being mounted close-

together are minimized. This all means a packaging density higher than ever before.

• Nominal operating power: 140 mW • Outstanding vibration and shock resistance.

Functional shock resistance:

750 m/s² {75G}

Destructive shock resistance:

1,000 m/s² {100G}

Functional vibration resistance:

10 to 55 Hz (at double amplitude of 3.3 mm .130 inch)

Destructive vibration resistance:

10 to 55 Hz (at double amplitude of 5 mm .197 inch)

SPECIFICATIONS

Contact

Arrangement	2 Form C	
Initial contact resistance, max. (By voltage drop 6 V DC 1A)	100 mΩ	
Contact material	Stationary: AgPd+Au clad.Movable: AgPd	
Rating	Nominal switching capacity (resistive load)	1 A 30 VDC 0.3 A 125 VAC
	Max. switching power (resistive load)	30 W, 37.5 VA
	Max. switching voltage	110 VDC, 125 VAC
	Max. switching current	1 A
	Min. switching capacity *1	10 μA 10 mVDC
Nominal operating power	Single side stable	140mW (1.5 to 12 VDC) 230mW (24 VDC)
	1 coil latching	100mW (1.5 to 12 VDC) 120mW (24 VDC)
Expected life (min. operations)	Mechanical (at 180 cpm)	5 × 10 ⁷
	Electrical (at 20 cpm)	1 A 30 V DC resistive
		0.3 A 125 V AC resistive

Remarks:

*1 Measurement at same location as "Initial breakdown voltage" section.

*2 Detection current: 10mA

*3 Nominal voltage applied to the coil, excluding contact bounce time.

*4 By resistive method, nominal voltage applied to the coil; contact carrying current: 1 A.

*5 Half-wave pulse of sine wave: 6 ms; detection time: 10 μs.

*6 Half-wave pulse of sine wave: 6 ms.

*7 Detection time: 10 μs.

*8 Refer to 8. Conditions for operation, transport and storage mentioned in Cautions for use

Characteristics

Initial insulation resistance*1		Min. 1,000MΩ (at 500V DC)
Initial breakdown voltage*2	Between open contacts	750 Vrms for 1min.
	Between contact sets	1,000 Vrms for 1min.
	Between contact and coil	1,500 Vrms for 1min.
Initial surge voltage	Between open contacts (10×160 μs)	1,500 V (FCC Part 68)
	Between contacts and coil (2×10 μs)	2,500 V (Bellcore)
Operate time [Set time]*3 (at 20°C)		Max. 4 ms (Approx. 2 ms) [Max. 4 ms (Approx. 2 ms)]
Release time (without diode) [Reset time]*3 (at 20°C)		Max. 4 ms (Approx. 1 ms) [Max. 4 ms (Approx. 2 ms)]
Temperature rise*4 (at 20°C)		Max. 50°C
Shock resistance	Functional*5	Min. 750 m/s ² {75G}
	Destructive*6	Min. 1,000 m/s ² {100G}
Vibration resistance	Functional*7	10 to 55 Hz at double amplitude of 3.3 mm
	Destructive	10 to 55 Hz at double amplitude of 5 mm
Conditions for operation, transport and storage*8 (Not freezing and condensing at low temperature)	Ambient temperature *2	-40°C to 85°C -40°F to 185°F
	Humidity	5 to 85% R.H.
Unit weight		Approx. 1 g .035 oz

Notes:

*1 This value can change due to the switching frequency, environmental conditions, and desired reliability level, therefore it is recommended to check this with the actual load.

*2 The upper limit for the ambient temperature is the maximum temperature that can satisfy the coil temperature rise. Under the packing condition, allowable temperature range is from -40 to +70°C -40 to +158°F

TYPICAL APPLICATIONS

- Telephone exchange, transmission equipment
- Communications devices
- Measurement devices
- Home appliances, and audio/visual equipment
- Handheld and portable products

ORDERING INFORMATION

Ex. AGQ 2 0 0 A 1 H Z

Contact arrangement	Operating function	Type of operation	Terminal shape	Coil voltage (DC)		Packing style
2: 2 Form C	0: Single side stable 1: 1 coil latching	0: Standard type (B.B.M.)	Nil: Standard PC board terminal A: Surface-mount terminal A type S: Surface-mount terminal S type	1H: 1.5V 03: 3V 4H: 4.5V 06: 6V	09: 9V 12: 12V 24: 24V	Nil: Tube packing Z: Tape and reel packing (piked from 5/6/7/8 pin side)

Note: Tape and reel packing symbol "Z" is not marked on the relay. "X" type tape and reel packing (picked from 1/2/3/4-pin side) is also available. Suffix "X" instead of "Z".

TYPES AND COIL DATA (at 20°C 68°F)

(1) Standard PC board terminal

Operating Function	Coil Rating, V DC	Part No.	Pick-up voltage, V DC (max.) (initial)	Drop-out voltage, V DC (min.) (initial)	Nominal operating current, mA (±10%)	Coil resistance, Ω (±10%)	Nominal operating power, mW	Max. allowable voltage, V DC
		Standard PC board terminal						
Single side stable	1.5	AGQ2001H	1.13	0.15	93.8	16	140	2.25
	3	AGQ20003	2.25	0.3	46.7	64.2	140	4.5
	4.5	AGQ2004H	3.38	0.45	31	145	140	6.75
	6	AGQ20006	4.5	0.6	23.3	257	140	9
	9	AGQ20009	6.75	0.9	15.5	579	140	13.5
	12	AGQ20012	9	1.2	11.7	1,028	140	18
	24	AGQ20024	18	2.4	9.6	2,504	230	28.8

Operating Function	Coil Rating, V DC	Part No.	Set voltage, V DC (max.) (initial)	Reset voltage, V DC (max.) (initial)	Nominal operating current, mA (±10%)	Coil resistance, Ω (±10%)	Nominal operating power, mW	Max. allowable voltage, V DC
		Standard PC board terminal						
1 coil latching	1.5	AGQ2101H	1.13	1.13	66.7	22.5	100	2.25
	3	AGQ21003	2.25	2.25	33.3	90	100	4.5
	4.5	AGQ2104H	3.38	3.38	22.2	202.5	100	6.75
	6	AGQ21006	4.5	4.5	16.7	360	100	9
	9	AGQ21009	6.75	6.75	11.1	810	100	13.5
	12	AGQ21012	9	9	8.3	1,440	100	18
	24	AGQ21024	18	18	5.0	4,800	120	36

Standard packing: 50 pcs. in an inner package (tube); 1,000 pcs. in an outer package

(2) Surface-mount terminal

Operating Function	Coil Rating, V DC	Part No.		Pick-up voltage, V DC (max.) (initial)	Drop-out voltage, V DC (min.) (initial)	Nominal operating current, mA (±10%)	Coil resistance, Ω (±10%)	Nominal operating power, mW	Max. allowable voltage, V DC
		Tube packing	Tape and reel packing						
Single side stable	1.5	AGQ200○1H	AGQ200○1HZ	1.13	0.15	93.8	16	140	2.25
	3	AGQ200○03	AGQ200○03Z	2.25	0.3	46.7	64.2	140	4.5
	4.5	AGQ200○4H	AGQ200○4HZ	3.38	0.45	31	145	140	6.75
	6	AGQ200○06	AGQ200○06Z	4.5	0.6	23.3	257	140	9
	9	AGQ200○09	AGQ200○09Z	6.75	0.9	15.5	579	140	13.5
	12	AGQ200○12	AGQ200○12Z	9	1.2	11.7	1,028	140	18
	24	AGQ200○24	AGQ200○24Z	18	2.4	9.6	2,504	230	28.8

Operating Function	Coil Rating, V DC	Part No.		Set voltage, V DC (max.) (initial)	Reset voltage, V DC (max.) (initial)	Nominal operating current, mA (±10%)	Coil resistance, Ω (±10%)	Nominal operating power, mW	Max. allowable voltage, V DC
		Tube packing	Tape and reel packing						
1 coil latching	1.5	AGQ210○1H	AGQ210○1HZ	1.13	1.13	66.7	22.5	100	2.25
	3	AGQ210○03	AGQ210○03Z	2.25	2.25	33.3	90	100	4.5
	4.5	AGQ210○4H	AGQ210○4HZ	3.38	3.38	22.2	202.5	100	6.75
	6	AGQ210○06	AGQ210○06Z	4.5	4.5	16.7	360	100	9
	9	AGQ210○09	AGQ210○09Z	6.75	6.75	11.1	810	100	13.5
	12	AGQ210○12	AGQ210○12Z	9	9	8.3	1,440	100	18
	24	AGQ210○24	AGQ210○24Z	18	18	5.0	4,800	120	36

○: For each surface-mounted terminal variation, input the following letter.

A type: A, S type: S

- Standard packing: 50 pcs. (tube), 900 pcs. (tape and reel) in an inner package; 1,000 pcs. (tube), 1,800 pcs. (tape and reel) in an outer package.
- Specified value of pick-up, drop-out, set and reset voltage is with the condition of square wave coil pulse.

DIMENSIONS

mm inch

1. PC board terminal

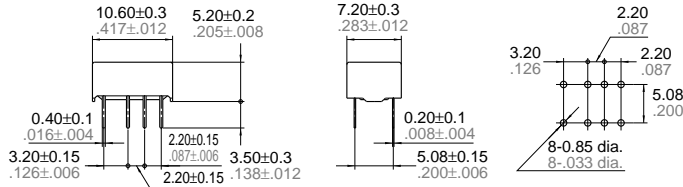
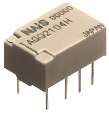

Tolerance: $\pm 0.1 \pm .004$

PC board pattern

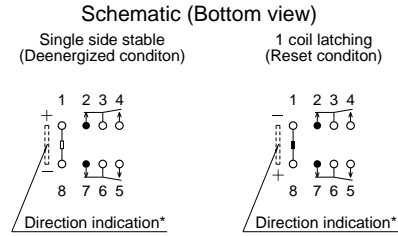

2. Surface-mount terminal

A type

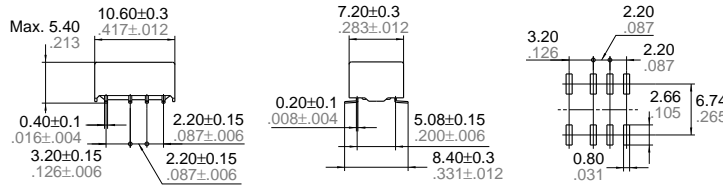
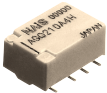

Tolerance: $\pm 0.1 \pm .004$

S type

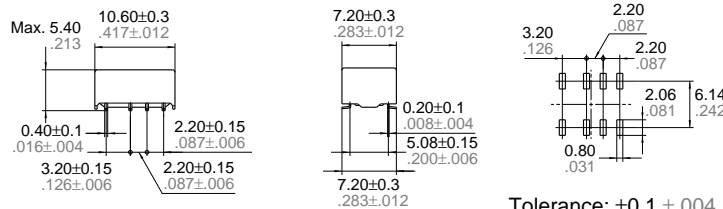

REFERENCE DATA

1. Max. switching capacity

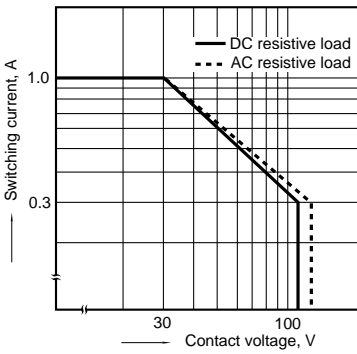

2. Life curve

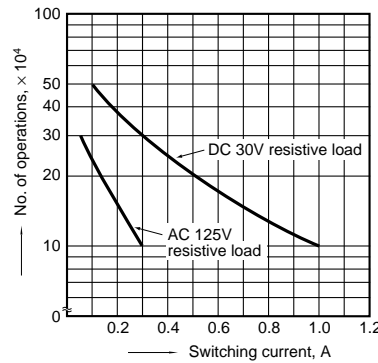

rated operating voltage should be applied to the coil for 10 ms or more.

2. Coil connection

When connecting coils, refer to the wiring diagram to prevent mis-operation or malfunction.

3. External magnetic field

Since AGQ relays are highly sensitive polarized relays, their characteristics will be affected by a strong external magnetic field. Avoid using the relay under that condition.

4. Cleaning

In automatic cleaning, cleaning with the boiling method is recommended. Avoid ultrasonic cleaning which subjects the relay to high frequency vibrations. It may cause the contacts to stick.

It is recommended that a fluorinated

hydrocarbon or other alcoholic solvent be used.

5. Packing style

1) The relay is packed in a tube with the relay orientation mark on the left side, as shown in the figure below.

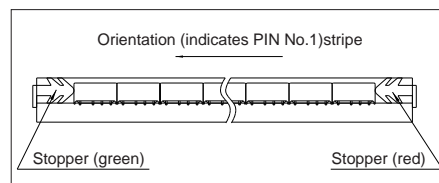
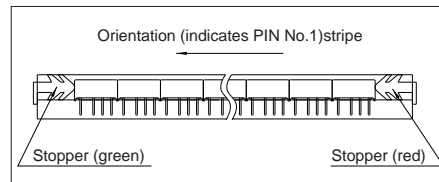

CAUTIONS FOR USE

1. Coil operating power

1) As a general rule, only a pure DC power supply should be used for the coil drive.

2) To ensure proper operation, the voltage applied to both terminals of the coil should be $\pm 5\%$ (at 20°C 68°F) the rated operating voltage of the coil. Also, be aware that the pick-up and drop-out voltages will fluctuate depending on the ambient temperature and operating conditions.

3) The ripple factor for the voltage applied to the coil should be less than 5%.

4) For set and reset latching relays, the

2) Tape and reel packing

(1) Tape dimensions

(A type)

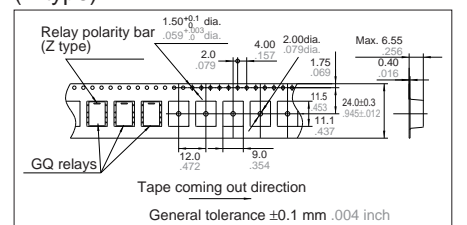

(S type)

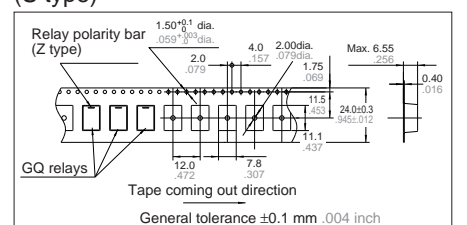

(2) Dimensions of plastic peel mm inch

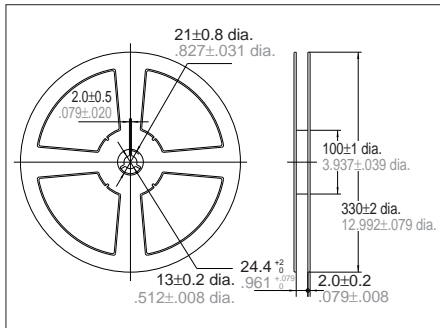

6. Automatic insertion

To maintain the internal function of the relay, the chucking pressure should not exceed the values below.

Chucking pressure in the direction A:

9.8 N {1 kgf} or less

Chucking pressure in the direction B:

9.8 N {1 kgf} or less

Chucking pressure in the direction C:

9.8 N {1 kgf} or less

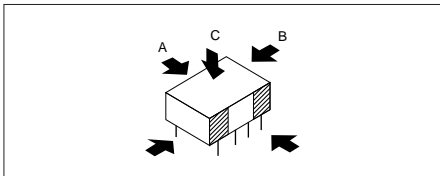

Please chuck the portion.

Avoid chucking the center of the relay. In addition, excessive chucking pressure to the pinpoint of the relay should be also avoided.

7. Soldering

1) When soldering standard PC board terminals, the following conditions are recommended.

(1) Preheating

Temperature 100°C 212°F

Time Within approx. 1minute

(2) Soldering

Temperature 250°C 482°F

Time Within approx. 5s

2) When soldering surface-mount terminals, the following conditions are recommended.

(1) IR (Infrared reflow) soldering method

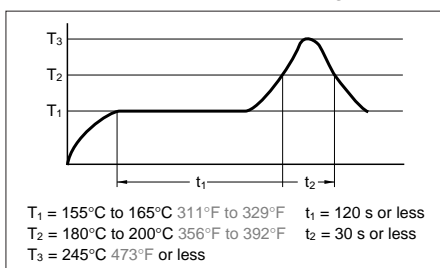

(2) Soldering iron method

Tip temperature: 280°C to 300°C

536°F to 572°F

Wattage: 30 to 60 W

Soldering time: within 5 s

(3) Other soldering methods

Check mounting conditions before using other soldering methods (hot-air, hot plate, pulse heater, etc.).

Remarks

• The temperature profile indicates the temperature of the soldered terminal on the surface of the PC board. The ambient temperature may increase excessively. Check the temperature under mounting conditions.

8. Conditions for operation, transport and storage

1) Ambient temperature, humidity, and atmospheric pressure during usage, transport, and storage of the relay:

(1) Temperature:

-40 to +85°C -40 to +185°F.

(temperature range under our standard packing style:

-40 to +70°C -40 to +158°F.)

(2) Humidity: 5 to 85% R.H.

(Avoid freezing and condensation.)

The humidity range varies with the temperature. Use within the range indicated in the graph below.

(3) Atmospheric pressure: 86 to 106 kPa

Temperature and humidity range for usage, transport, and storage:

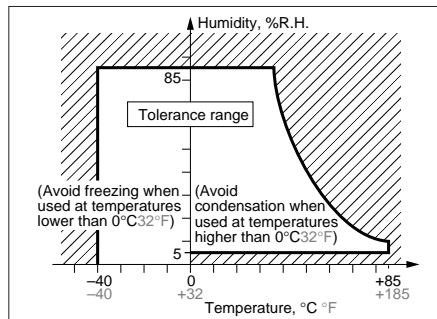

2) Condensation

Condensation forms when there is a sudden change in temperature under high temperature, high humidity conditions. Condensation will cause deterioration of the relay insulation.

3) Freezing

Condensation or other moisture may freeze on the relay when the temperature is lower than 0°C 32°F. This causes problems such as sticking of movable parts or operational time lags.

4) Low temperature, low humidity environments

The plastic becomes brittle if the relay is exposed to a low temperature, low humidity environment for long periods of time.

5) Storage procedures for surface-mount terminal types

Since the relay is very sensitive to humidity, it is packed in humidity-free, hermetically sealed packaging. When storing the relay, be careful of the following points:

(1) Be sure to use the relay immediately after removing it from its sealed package.

(2) When storing the relay for long periods of time after removing it from its sealed package, we recommend using a humidity-free bag with silica gel to prevent subjecting the relay to humidity.

Furthermore, if the relay is solder mounted when it has been subjected to excessive humidity, cracks and leaks can occur. Be sure to mount the relay under the required

mounting conditions.

9. Others

1) Heat, smoke, and even a fire may occur if the relay is used in conditions outside of the allowable ranges for the coil ratings, contact ratings, operating cycle lifetime, and other specifications. Therefore, do not use the relay if these ratings are exceeded.

Also, make sure that the relay is wired correctly. Incorrect wiring may cause unexpected events or the generation of heat or flames.

2) If the relay has been dropped, the appearance and characteristics should always be checked before use.

3) The cycle lifetime is defined under the standard test condition specified in the JIS* C 5442-1996 standard (temperature 15 to 35°C 59 to 95°F, humidity 25 to 75%). Check this with the real device as it is affected by coil driving circuit, load type, activation frequency, activation phase, ambient conditions and other factors. Also, be especially careful of loads such as those listed below.

(1) When used for AC load-operating and the operating phase is synchronous.

Rocking and fusing can easily occur due to contact shifting.

(2) High-frequency load-operating

When high-frequency opening and closing of the relay is performed with a load that causes arcs at the contacts, nitrogen and oxygen in the air is fused by the arc energy and HNO₃ is formed. This can corrode metal materials.

Three countermeasures for these are listed here.

- Incorporate an arc-extinguishing circuit.
- Lower the operating frequency
- Lower the ambient humidity

4) Latching relays are shipped from the factory in the reset state. A shock to the relay during shipping or installation may cause it to change to the set state.

Therefore, it is recommended that the relay be used in a circuit which initializes the relay to the required state (set or reset) whenever the power is turned on.

5) Check the ambient conditions when storing or transporting the relays and devices containing the relays. Freezing or condensation may occur in the relay, causing functional damage. Avoid subjecting the relays to heavy loads, or strong vibration and shocks.

6) We recommend latching type when using in applications which involve lengthy duty cycles.

7) If silicone materials (e.g., silicone rubbers, silicone oils, silicone coating agents, silicone sealers) are used in the vicinity of the relay, the gas emitted from the silicone may adhere to the contacts of the relay during opening and closing and lead to improper contact. If this is the case, use a material other than silicone.

*Japanese Industrial Standards